

Exploring the Lived Experience After a Diagnosis of Li Fraumeni Syndrome

Kirsten Bartels¹, MSc Candidate, Jenna Scott², MS, and Jennifer Nuk², MSc

1. UBC, Department of Medical Genetics, Vancouver, British Columbia, Canada

2. BC Cancer Agency, Hereditary Cancer Program, Vancouver, British Columbia, Canada

UBC Genetic Counselling Training Program

Directed Studies Project

13 May 2011

Li Fraumeni Syndrome (LFS)

Prevalence may be as high as 1:20 000

LFS tumour types:

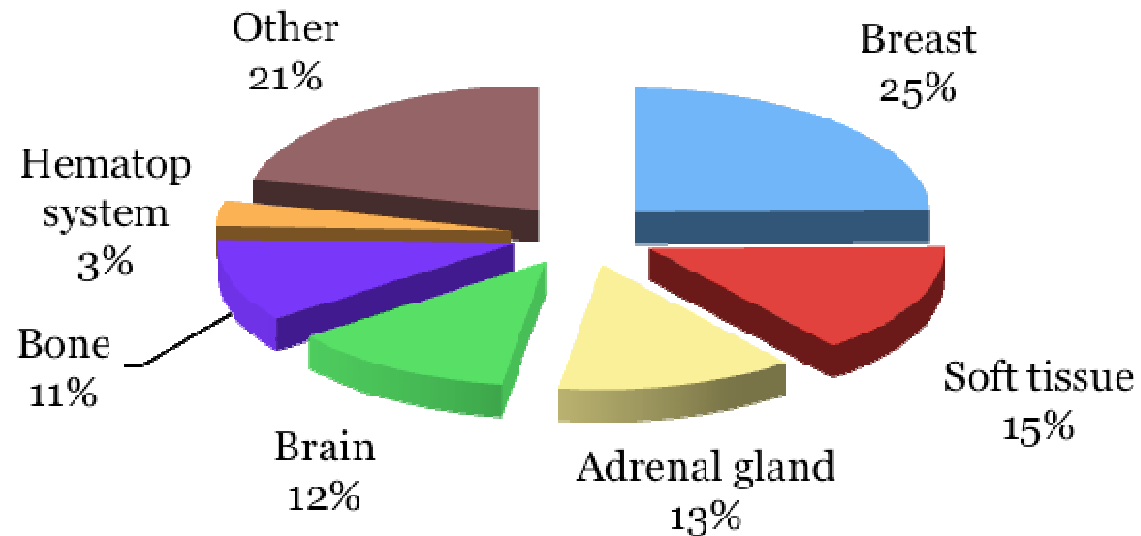

Adapted from: Olivier M et al. Cold Spring Harb Perspect Biol 2010;2:a001008
Data from IARC TP53 Germline Database (R13, November 2008, <http://www-p53.iarc.fr/Germline.html>).

LFS

Germline *TP53* mutations

≤ 50% by age 40

≤ 90% by age 60

Increased risk for cancer in children - up to 20% risk

- Estimating an individual's lifetime risk challenging due to risk modifiers
 - Gender
 - Mutation type/site
 - MDM2 SNP309 (negative p53 regulator)
 - Exposure (XRT, smoking, other?)
 - Generation (anticipation)

LFS

Recommended surveillance:

Children

- Annual physical examination, CBC, urinalysis
- Annual abdominal ultrasound
- Additional organ based screening depending on family history

Adults

- Annual physical examination (with skin and neuro evaluation)
- Annual CBC, urinalysis
- *For women:* clinical breast exam q6 months at 20-25 yrs
- *For women:* annual mammogram at 20-25 yrs
- Consideration of annual full body MRI or PET scan

LFS

American Society of Clinical Oncology statement for genetic testing of hereditary cancers (2010):

1. individual being tested has a personal or family history suggestive of genetic cancer susceptibility,
2. the genetic test can be adequately interpreted, and
3. the test results have accepted clinical utility

→ Lack of comprehensive clinical management options calls into question the clinical utility and the value individuals who opt for this testing derive from it

LFS

- Unique counselling challenges created by:
 - Lack of a defined effective plan for disease management
 - Relatively high penetrance and possible anticipation (among other risk modifiers)
 - Increased cancer risk during childhood
- May have unique psychosocial experiences

Previous LFS Psychosocial Investigation

Peterson *et al.* (2008)

- Greater cancer-specific distress associated with:
 - lower quality of life
 - > perceived risk of having a mutation
 - no personal history of cancer
 - ↑ number of FDRs with cancer

Previous LFS Psychosocial Investigation

Lammens *et al.* (2010)

- Uptake and psychosocial consequences of genetic testing:
 - Certainty about their/children's cancer risk - important psychological benefit of genetic testing
 - LFS-related distress associated with lack of social support
 - Unfavorable test result did not result in adverse short-term psychological effects



Previous LFS Psychosocial Investigation

Oppenheim *et al.* (2001)

- Families psychologically fragile
- Interactions and thinking patterns related to family history of repeated cancer occurrence
- Fear of transmitting doom and death
(their parents experience and their own thoughts on childbearing)
- Genetic testing awoke disconcerting and unsolved questions



Purpose

To explore descriptively the overall experiences, perceptions and support needs of individuals since their diagnosis of LFS by *TP53* genetic testing.

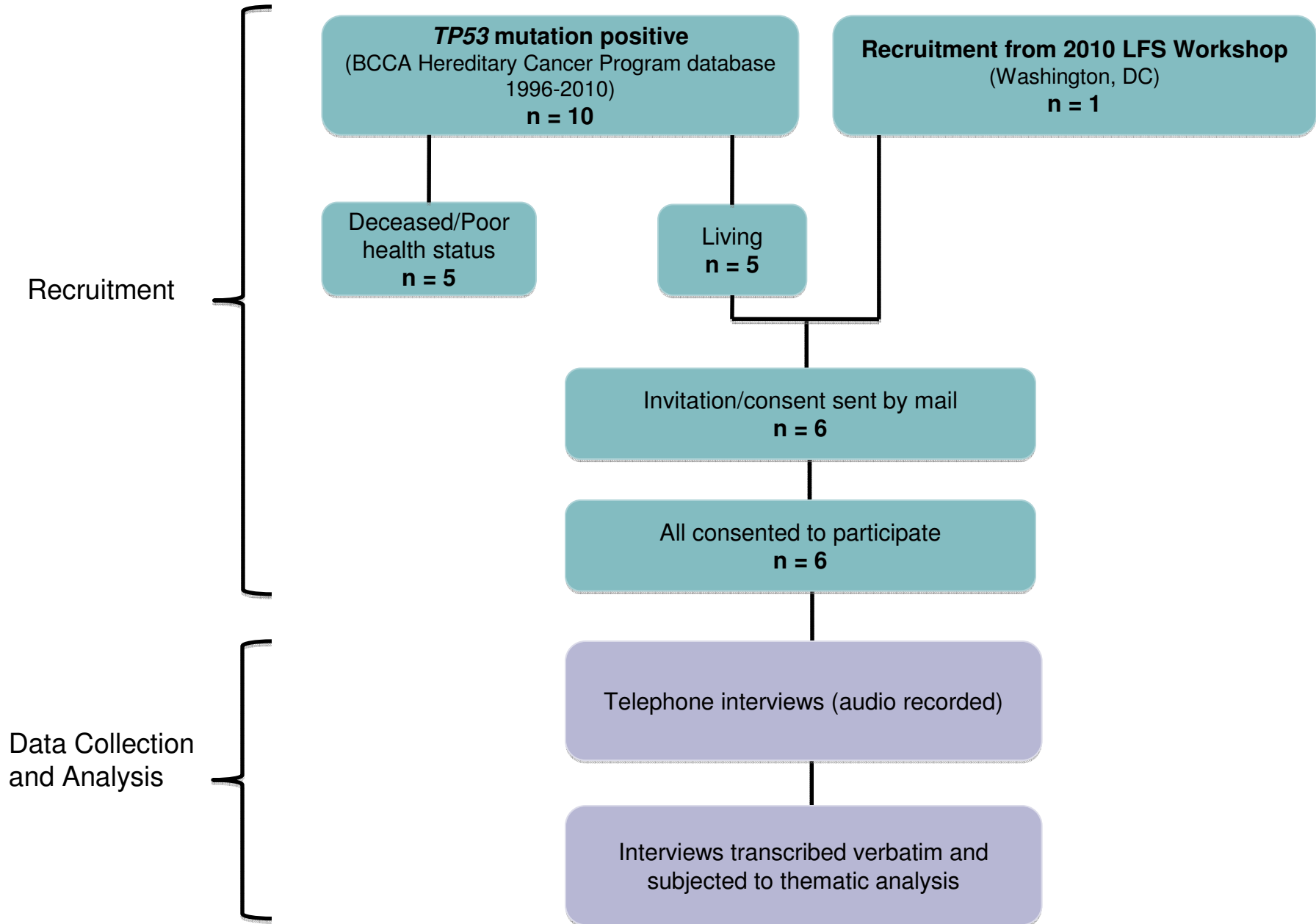

Data Collection
and Analysis

Telephone interviews (audio recorded)

- Sociodemographic characteristics
- Personal and family history of cancer
- Experience with genetic testing/counselling
- Experience living with a positive result
 - General impacts on life
 - Perception of health
 - Future planning
 - Need for social support

Interviews transcribed verbatim and
subjected to thematic analysis

1. Become familiar with the data through transcription, reading and re-reading data and noting down initial ideas
2. Independent systematic generation of initial codes – (KB and JN)
3. Collation of codes into themes and subthemes – (KB and JN)

Results

Study ID	Sex	Age (yrs)	Marital status	# of children	Ethnicity	Level of education	Personal cancer history	Time since diagnosis (yrs)
LE-01	F	31	Married	0	Caucasian	High School	Yes (sarcoma, breast)	14
LE-02	M	53	Married	3	Caucasian	University	Yes (skin)	≤ 3
LE-03	M	51	In relationship	0	Caucasian	High School	Yes (sarcoma, liposarcoma, leiomyosarcoma x2, abdominal, CRC)	12
LE-04	F	28	In relationship	0	Caucasian	University	Yes (rhabdomyosarcoma)	6
LE-05	F	57	Single	0	Caucasian	University	Yes (breast, sarcoma)	10
LE-06	F	29	Married	0	Caucasian	University	No	≤ 3

Age - range: 28-57 years, median: 41 years

Time since diagnosis - range: ≤ 3-14 years, median: 8 years

Map of Emergent Themes and Sub-themes

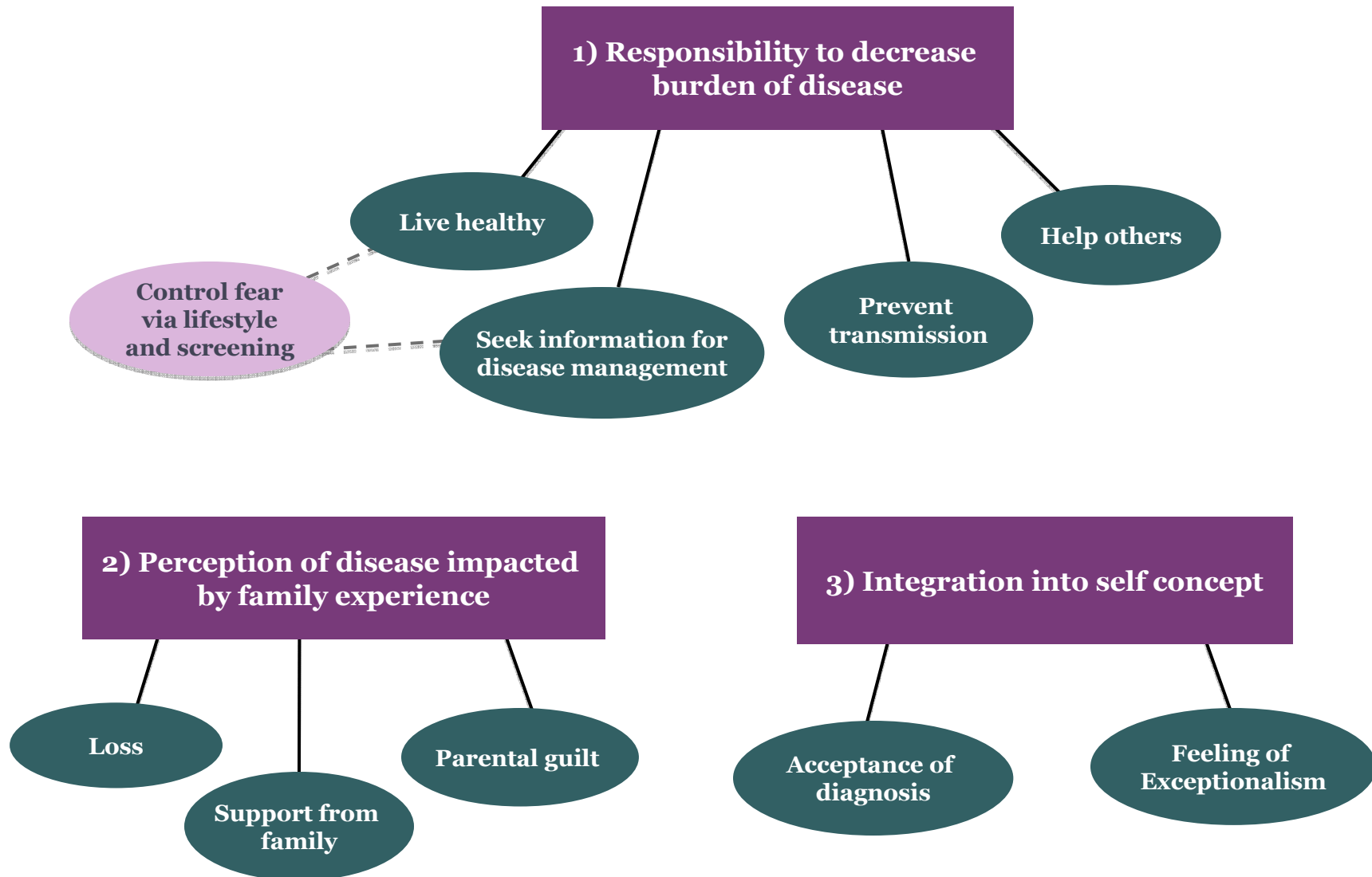

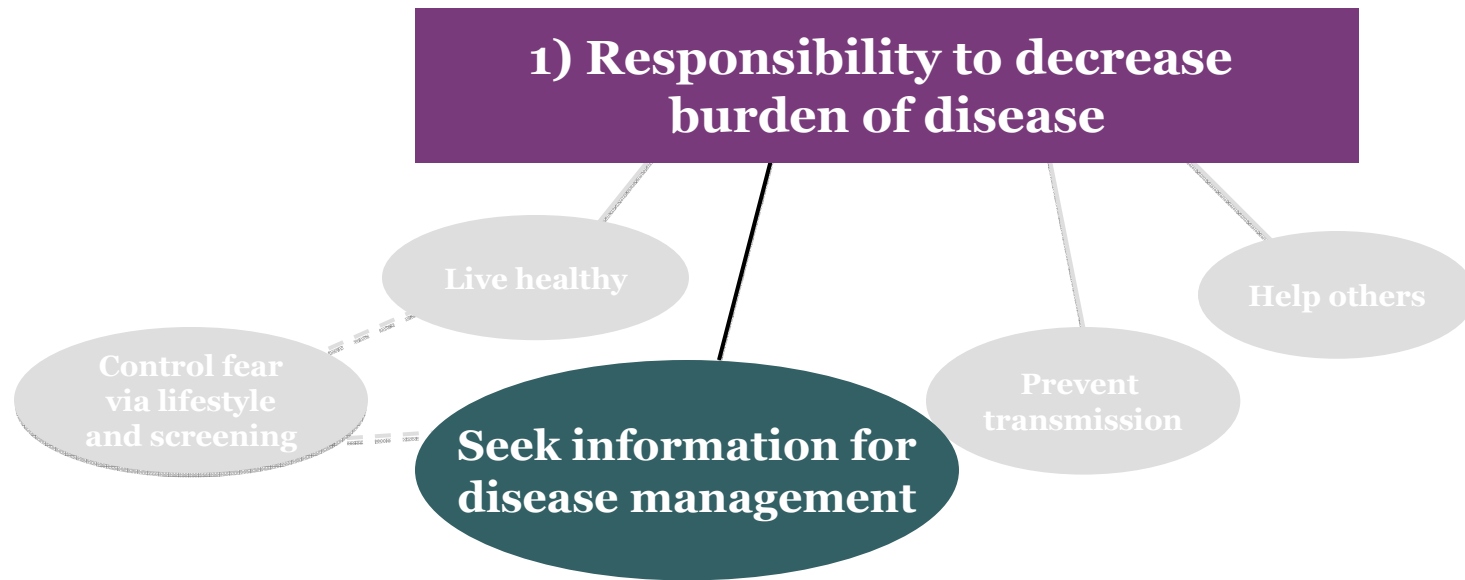

- Responsibility to undergo genetic counselling and/or testing in order to know their cancer risk and to inform proper disease management
- Included appropriate screening options, prophylactic surgery and cancer therapies

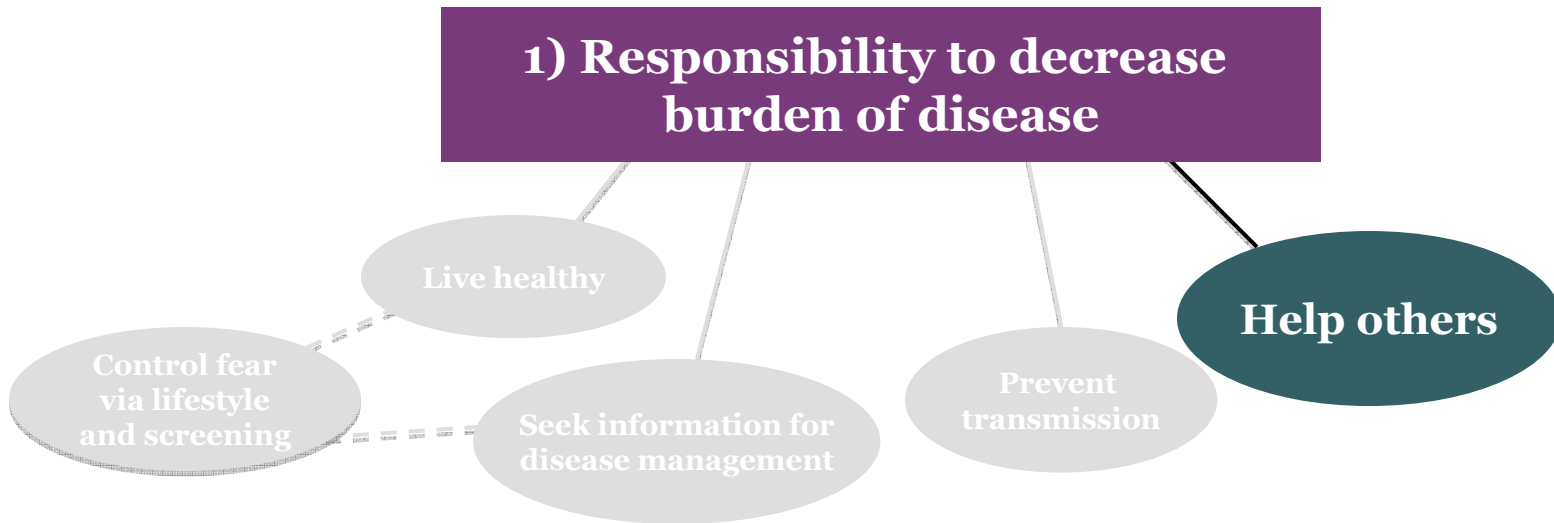

- Seek genetic counselling and/or testing to inform other family members and to contribute to LFS research

“...I don’t have any siblings left, I don’t have any children, I don’t have any family, it’s just me and my mom are all that’s left and the idea is if people like us don’t help who the heck will? If for some reason you have been blessed with survival, you’ve survived you kind of have a moral obligation.”
(LE-05)

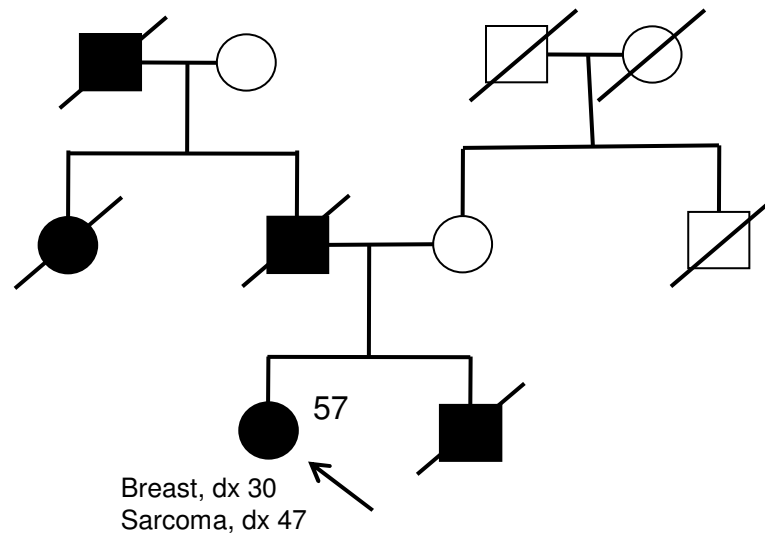

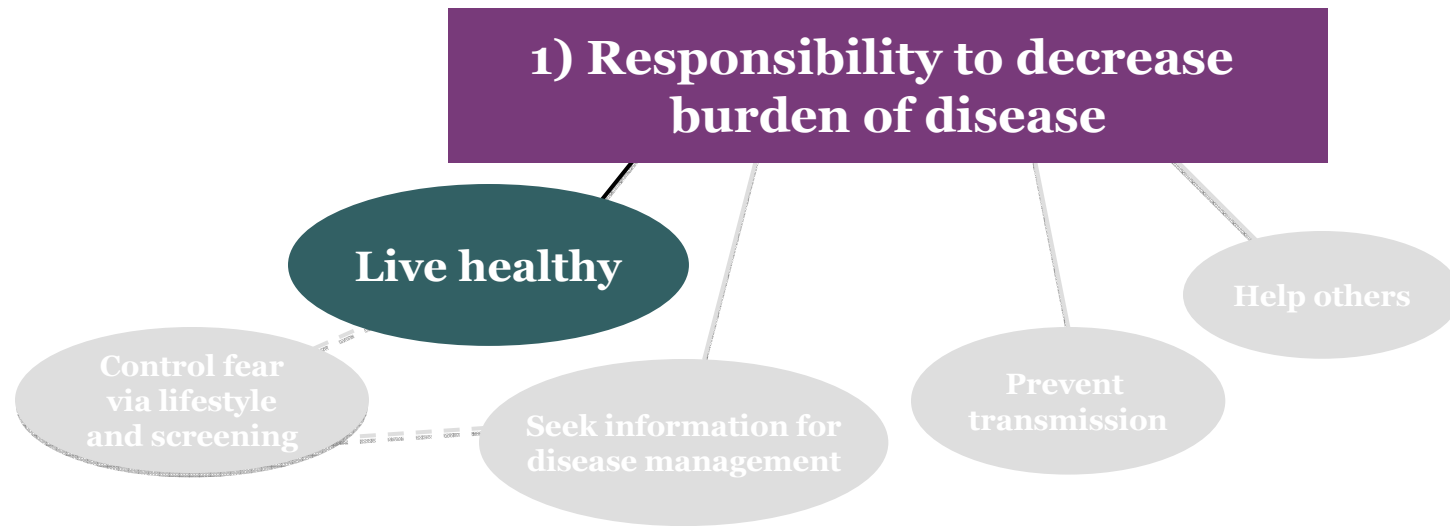

- Responsibility to live healthy since their diagnosis with LFS
- Maintain a healthy diet, regular exercise and avoid potentially harmful exposures that may increase their risk to develop cancer (ie smoking, x-rays)

“...I feel that its um the most important thing is keeping my immune system really strong because um if malignancies do come about, and that can happen, it’s my immune systems job to kick in and um destroy the, the cells that are um that are um out of control...” (LE-01)

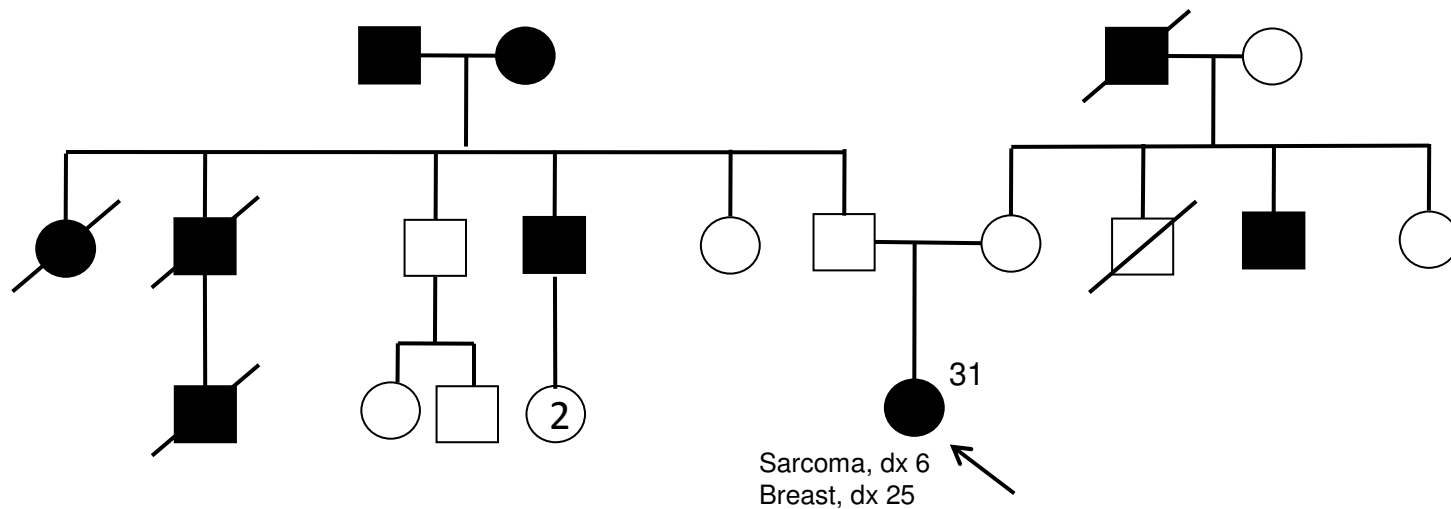

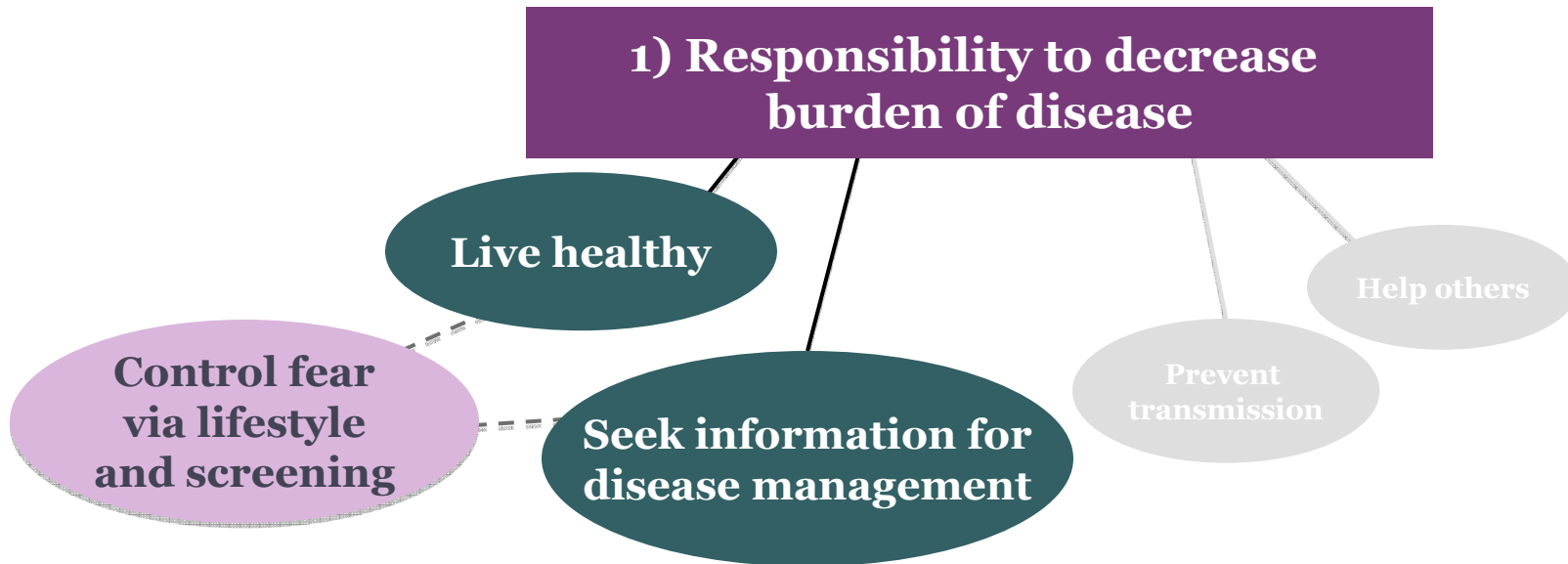

- A number of participants also maintained a healthy lifestyle and regular cancer screening practices as ways to control/reduce their fear of developing cancer

“...I feel like a have enough information [about LFS] to...for it to be useful for me not to worry because I know that, ya know, there is ways to help kind of like lower my risk and get screened and that kind of stuff so it makes me like at ease I guess and not so worried about it...” (LE-04)

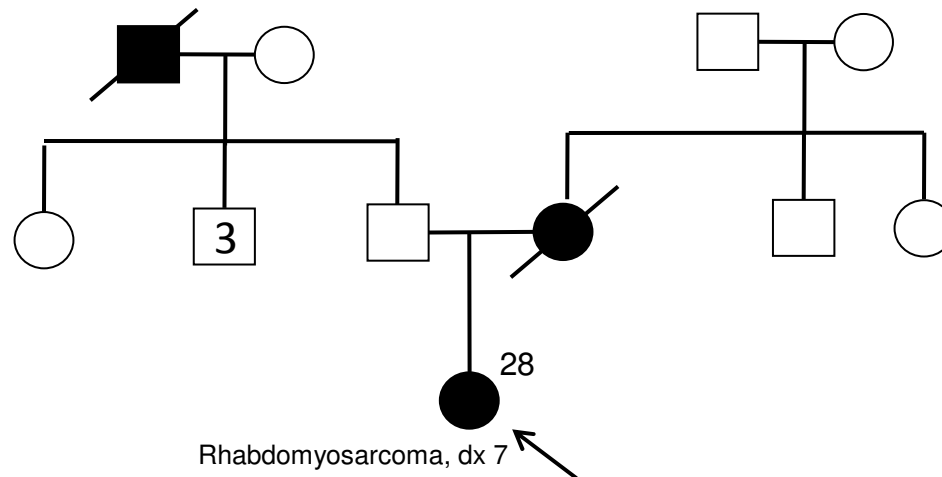

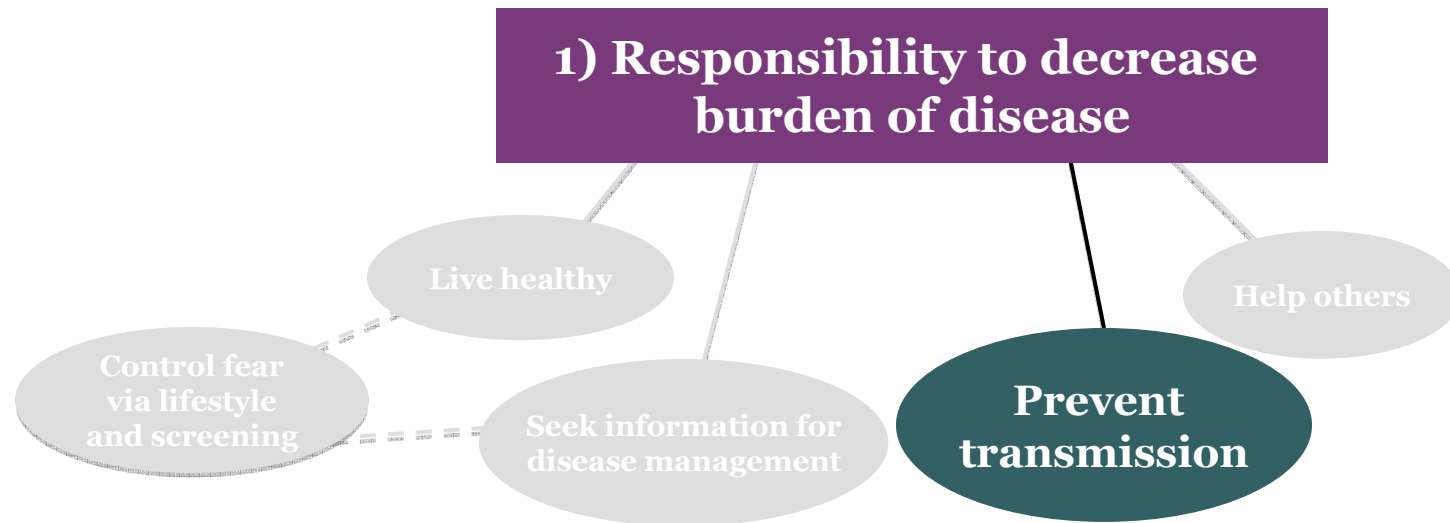

- Repeatedly expressed a sense of responsibility not to pass down the gene mutation/LFS to future children
- Preventing the transmission of cancer and death
- Complex decision making process in order to avoid transmission of LFS
→ preimplantation genetic diagnosis (PGD), adoption, forgo childbearing

“I just can’t imagine having children and leaving it up to chance, I think that if to, to, ya know, watch your child go though that, god forbid you lose a child, the whole time you’d blame yourself because you would think I knew and I could have prevented this and I didn’t.” (LE-06)

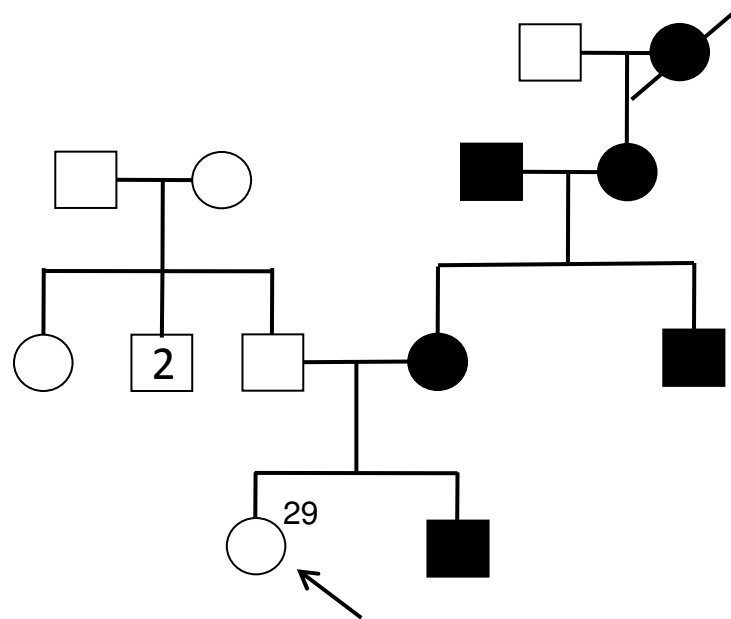

2) Perception of disease impacted by family experience

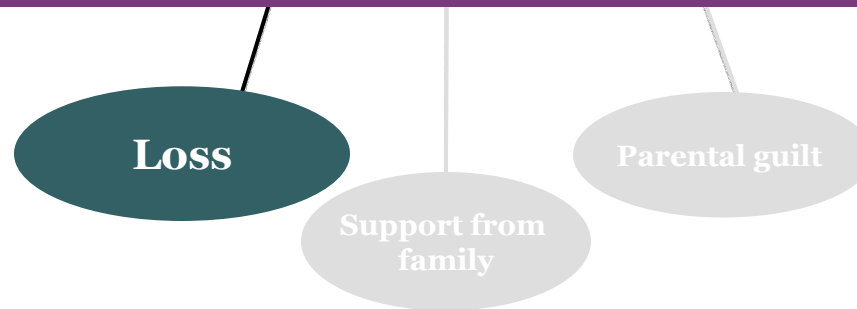

- Perception of LFS was impacted by the family experience for all participants in various ways
- Perceptions were *negatively* impacted by loss experienced by the family
- Most common - death of close family members due to cancer, also loss of the family structure
- Survivorship had positive impact

“...um especially having had so many relatives pass away I think I’m one of the only ones that that has gotten a second or third chance to um but one of the biggest impacts is that in good conscious I don’t feel like I will ever have children naturally ya and that’s not because I can’t, its just far too scary for me.” (LE-01)

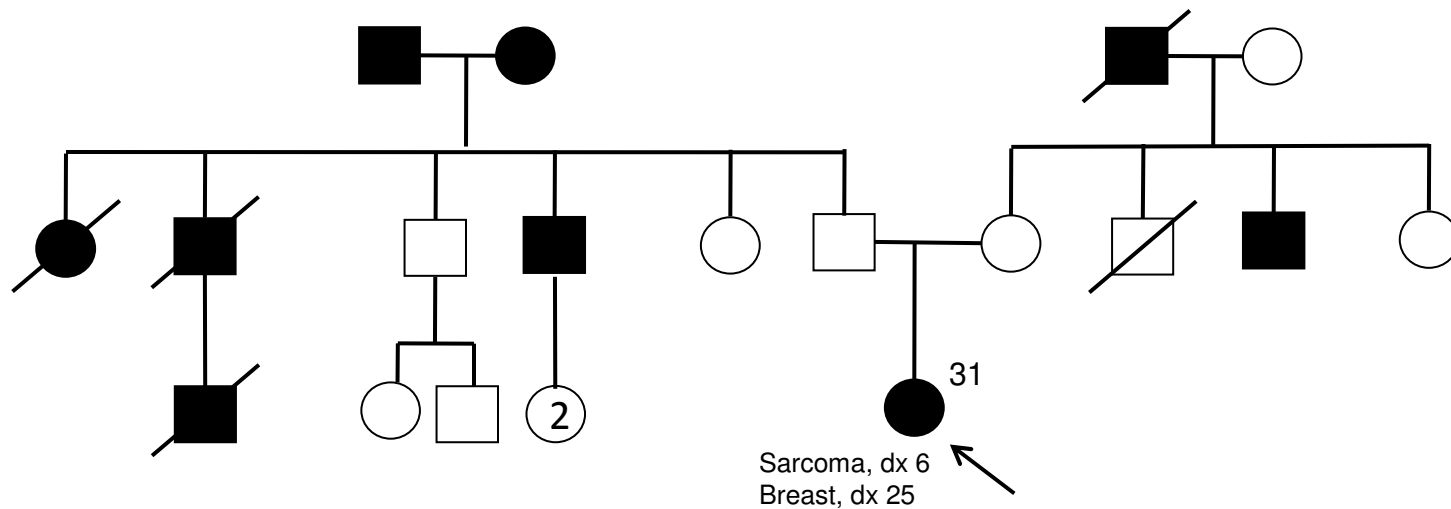

2) Perception of disease impacted by family experience

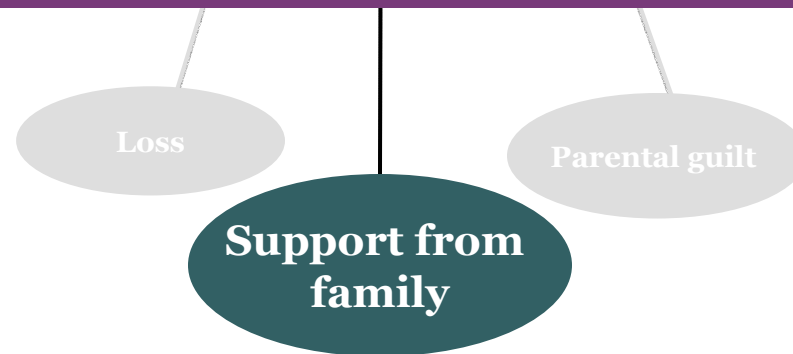

- Positively impacted when an individual had received strong family support
- Participants spoke about the significance of receiving family support during disease treatment as well as decisions with family planning

2) Perception of disease impacted by family experience

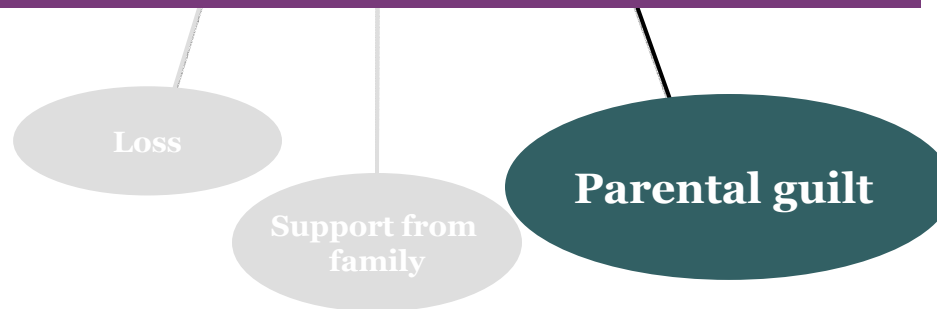

- Participants discussed prevention of transmission in reaction to the guilt felt by their parents having passed on the gene mutation to them

“...I know how my mom feels, and her guilt with that, and she didn’t know, that was the even worse thing right in that seeing how much guilt she carries and for her to not have even known and not to have been able to prevent it then I just I think I would be the same way and I think it would be even harder for me.” (LE-06)

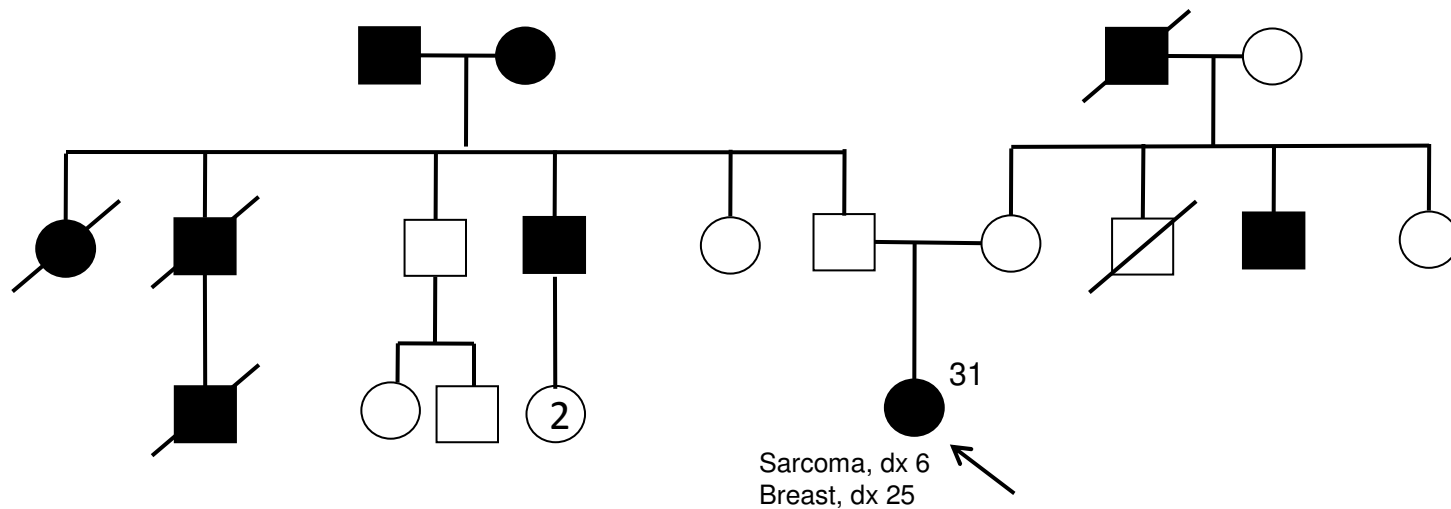

3) Integration into self concept



- Integrated diagnosis of LFS into their self-concept in various ways
- All participants had accepted LFS as a part of who they are
→ how they view their life presently, how they see the future

3) Integration into self concept

Acceptance of
diagnosis

Feeling of
Exceptionalism

- Participants expressed feelings of exceptionalism or uniqueness when compared to others who do not have LFS
- Unique perspective on life and mortality
- Increased cancer risk compared to the general population
- Treated differently by family members because of their diagnosis

“...as a teen I thought I was just doomed and so I didn’t make any plans as far as um university (laughs) because uh I thought I just need to get the most of life at the time in my naive teen mind. (laughs) Um as I’ve gotten older I’ve been able to commit to some more long term things like um buying a house and um uh but even the concept of saving for retirement is a little absurd to me (laughs) um because I really don’t know what’s going to happen in 10, 10 years. So, so that’s, that’s a real juxtaposition in that like uh your really...society is such that your supposed to save for retirement, plan for a long life and that could definitely be in my future but at the same time it could just as easily not.” (LE-01)

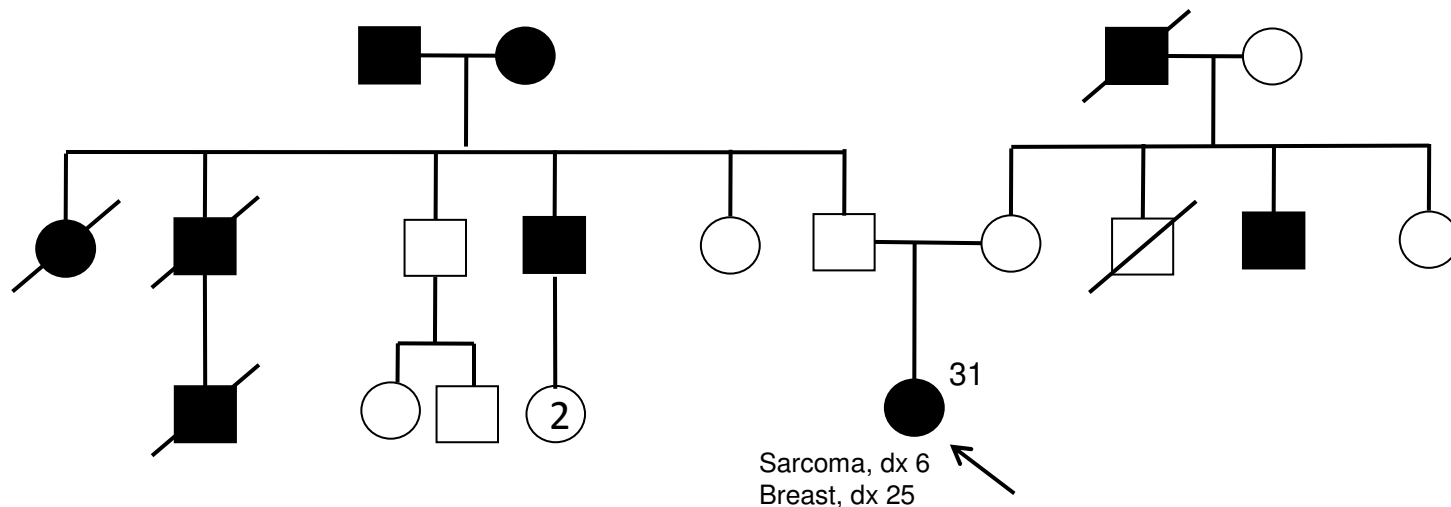



Discussion

1. Experience with genetic counselling and testing
2. The importance of loss within the family due to cancer
3. The importance of family (social) support
4. Integration of genetic diagnosis into self-concept
5. Family planning decisions complex, choices limited by disease

Discussion

Experience with genetic counselling and testing

- Overall experience was positive - would do genetic testing again
- Need to know cancer risk and to inform proper disease management
- Need to inform other family members and to contribute to LFS research
- Lammens *et al* - obtain certainty of cancer risk, to help others as well as to plan appropriate surveillance
- High perceived expectation about controllability of the disease?

Discussion

The importance of loss within the family due to cancer

- *Negative* impact on our participants' perception of the disease
- Peterson, *et al* - greater cancer-specific distress associated with greater number of first degree relatives affected with cancer
- Oppenheim, *et al* - LFS-affected families were psychologically fragile, that their interactions and thinking patterns were related to a family background plagued by the repeated occurrence of cancer

Discussion

The importance of family (social) support

- *Positive* impact on participants' perception of the disease
- den Heijer, *et al* - “of paramount importance in the long-term adaptation to being at risk for hereditary breast cancer”
- Lammens, *et al* - greater LFS-related distress associated with lack of social support
- Need social support? “No.”

Discussion

Integration of genetic diagnosis into self-concept

- Genetic diagnosis different from diagnosis of an illness → can impact self-concept (self-perception of future health, body image, self-worth and identity)
- Self-concept important for maintenance of physical and psychosocial well-being
- Feeling of exceptionalism lead to feelings of stigmatization in two of our participants
- Altered self-views can play a role in health behaviors, lead to psychological distress and interfere with planning for one's future

Discussion

Family planning decisions complex, choices limited by disease

- Responsibility to prevent the transmission of cancer and death to their children
- Reaction to the guilt felt by their parents having passed on the gene mutation to them
- Oppenheim, *et al* - fear of “transmitting doom and death”, questioned whether their parents would have had them had they known their genetic test result, these attitudes played a role in their own decision-making in family planning



Limitations

- Small numbers
- Similar demographics
 - Ethnicity
 - Education
 - Number of children
 - BC residents

Conclusions

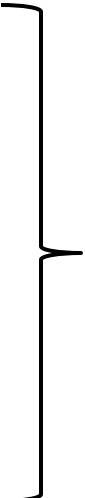
1. Experience with genetic counselling and testing → **positive, valuable**
 2. The importance of loss within the family due to cancer
 3. The importance of family (social) support
 4. Integration of genetic diagnosis into self-concept
 5. Family planning decisions complex, choices limited by disease
- 
- Important to assess and discuss during genetic counselling and testing process
 - After diagnosis - may need social support in absence of family and friend support
 - Need further study!



Thank you!

Jennifer Nuk

Jenna Scott

Hereditary Cancer Program

BC Cancer Agency Molecular Laboratory

Anita Dircks

Patricia Birch

Stephanie Keiffer

UBC Genetic Counselling Program

My classmates